



FLATBED APPLICATORS



PRODUCT CATALOGUE

February 2024

CWT WORKTOOLS

FLATBED APPLICATOR AND WORKTABLE

With our new series of flatbed applicators, we are taking steps to make our equipment even more versatile to meet the increasing demands of controlled laminating processes.

Our goal remains the same: to build user-friendly machinery that enables your business to achieve the best possible output in terms of production and quality capacity and we have implemented many new functions for controlling pressure and speed to make that happen.

Additionally, we have invented a new way to ship semi- and fully assembled applicators in a vertical position that makes installation fast and easy, even in confined spaces.

This solution for transportation also reduces space and will ensure a smaller environmental footprint.

Visit cwtworktools.com to see our complete range of products.

AREAS OF APPLICATION

- Apply premask application tape on cut vinyl
- Laminate large format prints and artwork
- Mount self-adhesive vinyl and prints to boards and panels
- For rigid and soft substrates
- Protective film on glass
- Create multi-material panels
- Car wrap preparations
- Traffic signs

And much more with time savings of up to 85%

PREMIUM SERIES

PNEUMATIC FLATBED APPLICATOR AND WORKTABLE

Our most popular and original classic model has been updated to new standards. Introducing our latest flatbed applicator, a robust production machine designed for uninterrupted long shifts.

Equipped with essential features such as a light table, electronic height adjustment, and an integrated cutting solution, it offers high production capacity and a worktable that accommodates a wide range of standard substrates and media widths available on the market.



Tested and proven!

Complies with CE, UL, ISO 9001 and ISO 14001.



“Our CWT flatbed applicator has become the centre of our production process.”

Frédéric Brühlhart - CEO, SICHTBAR Beschriftung

CWT PREMIUM

Model	CWT 1730 Premium	CWT 1736 Premium	CWT 1740 Premium	CWT 1747 Premium
Table length	3 000mm (9ft. 10in.)	3 640mm (11ft. 3in.)	4 000mm (13ft. 1in.)	4 720mm (15ft. 5 in.)
Table width	1 720mm (5ft. 8in.)	1 720mm (5ft. 8in.)	1 720mm (5ft. 8in.)	1 720mm (5ft. 8in.)
Length of working area	2 560mm (8ft. 8in.)	3 200mm (10ft. 6in.)	3 550mm (11ft. 7 in.)	4 270mm (14ft.)
Width of working area/roller width	1 650mm (5ft. 5in.)	1 650mm (5ft. 5in.)	1 650mm (5ft. 5in.)	1 650mm (5ft. 5in.)
Max. Thickness of substrate	70mm (0-2.7in.)	70mm (0-2.7in.)	70mm (0-2.7in.)	70mm (0-2.7in.)
Work height	750-900mm (2ft. 5in. - 2ft. 11in.)	750-900mm (2ft. 5in. - 2ft. 11in.)	750-900mm (2ft. 5in. - 2ft. 11in.)	750-900mm (2ft. 5in. - 2ft. 11in.)
Work height adjustment	Electronic	Electronic	Electronic	Electronic
Illuminated worktable	Included	Included	Included	Included
Bed surface	Safety glass + Cutting mat	Safety glass + Cutting mat	Safety glass + Cutting mat	Safety glass + Cutting mat
Pressure control	Pneumatic	Pneumatic	Pneumatic	Pneumatic
Roll holder for glide beam	Included	Included	Included	Included
Roll holder for bed end	Included on one side	Included on one side	Included on one side	Included on one side
Warranty	3 Year warranty	3 Year warranty	3 Year warranty	3 Year warranty

OPTIONS

Silent Compressor	Option	Option	Option	Option
Compressor Shelf	Option	Option	Option	Option
CWT Cut, long side *	Option	Option	Option	Option
CWT Cut, short side *	Option	Option	Option	Option
Pro Shaft 1700	Option	Option	Option	Option
Lower Roll Holder	Option	Option	Option	Option
Roll Cradle 450	Option	Option	Option	Option
Extra Roll Holder for bed end	Option	Option	Option	Option
Cutter Bench for 1700 series **	Option	Option	Option	Option
Charging station, USB A+C ***	Option	Option	Option	Option

* Brackets for Linear Cutter, available in two versions and are sold separately for the long side and short side.

** A bracket that fits a wide range of cutters and slitters, such as the Inqlet InBest Pro Cutter Bar™, and KeenCut Evolution2 and Evolution3™ SmartFold.

*** Integrated panel with 2x USB A (7,5W) and 2x USB C (50W)

REGULAR 1700 SERIES

PNEUMATIC FLATBED APPLICATOR AND WORKTABLE

Our most popular and original classic model has become an industry favorite among signmakers and digital printers. Regular series is now upgraded to feature a wider working width.

It is a robust production machine built for uninterrupted long shifts, equipped with all the essential features, high production capacity, and a worktable that accommodates a wide range of standard substrates and media widths available on the market.



Tested and proven!

Complies with CE, UL, ISO 9001 and ISO 14001.

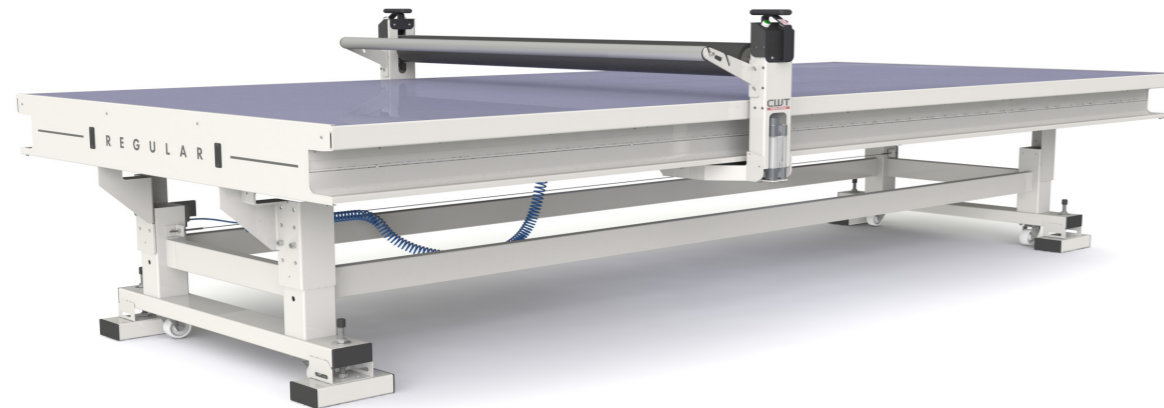

“Makes the task faster and easier than ever.”

Ted Redmer - Senior Digital Technology Manager, Alliance Franchise Brands

CWT REGULAR

Model	CWT 1730 Regular	CWT 1736 Regular	CWT 1740 Regular	CWT 1747 Regular
Table length	3 000mm (9ft. 10in.)	3 640mm (11ft. 3in.)	4 000mm (13ft. 1in.)	4 720mm (15ft. 5 in.)
Table width	1 720mm (5ft. 8in.)	1 720mm (5ft. 8in.)	1 720mm (5ft. 8in.)	1 720mm (5ft. 8in.)
Length of working area	2 560mm (8ft. 8in.)	3 200mm (10ft. 6in.)	3 550mm (11ft. 7 in.)	4 270mm (14ft.)
Width of working area/roller width	1 650mm (5ft. 5in.)	1 650mm (5ft. 5in.)	1 650mm (5ft. 5in.)	1 650mm (5ft. 5in.)
Max. Thickness of substrate	70mm (0-2.7in.)	70mm (0-2.7in.)	70mm (0-2.7in.)	70mm (0-2.7in.)
Work height	744-950mm (2ft.5in. - 3ft.1in.)	744-950mm (2ft.5in. - 3ft.1in.)	744-950mm (2ft.5in. - 3ft.1in.)	744-950mm (2ft.5in. - 3ft.1in.)
Work height adjustment	Manual - 4 steps	Manual - 4 steps	Manual - 4 steps	Manual - 4 steps
Bed surface	Safety glass + Cutting mat	Safety glass + Cutting mat	Safety glass + Cutting mat	Safety glass + Cutting mat
Pressure control	Pneumatic	Pneumatic	Pneumatic	Pneumatic
Roll holder for glide beam	Included	Included	Included	Included
Warranty	3 Year warranty	3 Year warranty	3 Year warranty	3 Year warranty

OPTIONS

CWT Light, illuminated worktable	Option	Option	Option	Option
CWT Lift kit, electronic work height adjustment	Option	Option	Option	Option
Silent Compressor	Option	Option	Option	Option
Compressor Shelf	Option	Option	Option	Option
CWT Cut, long side *	Option	Option	Option	Option
CWT Cut, short side *	Option	Option	Option	Option
Roll Holder for bed end	Option	Option	Option	Option
Lower Roll Holder	Option	Option	Option	Option
Roll Cradle 450	Option	Option	Option	Option
Cutter Bench for 1700 series **	Option	Option	Option	Option

* Brackets for Linear Cutter, available in two versions and are sold separately for the long side and short side.

** A bracket that fits a wide range of cutters and slitters, such as the InBest Pro Cutter Bar™, and KeenCut Evolution2 and Evolution3™ SmartFold.

REGULAR 1600 AND 2100 SERIES

PNEUMATIC FLATBED APPLICATOR AND WORKTABLE

Our most popular and original classic model has become an industry favorite among signmakers and digital printers.

It is a robust production machine built for uninterrupted long shifts, equipped with all the essential features, high production capacity, and a worktable that accommodates a wide range of standard substrates and media widths available on the market.



Tested and proven!

Complies with CE, UL, ISO 9001 and ISO 14001.

“We’ve had this table for 6 months now and I would say it has already paid for itself.”

Rick Alan Lenz - Owner FASTSIGNS, Greenville, South Carolina, USA

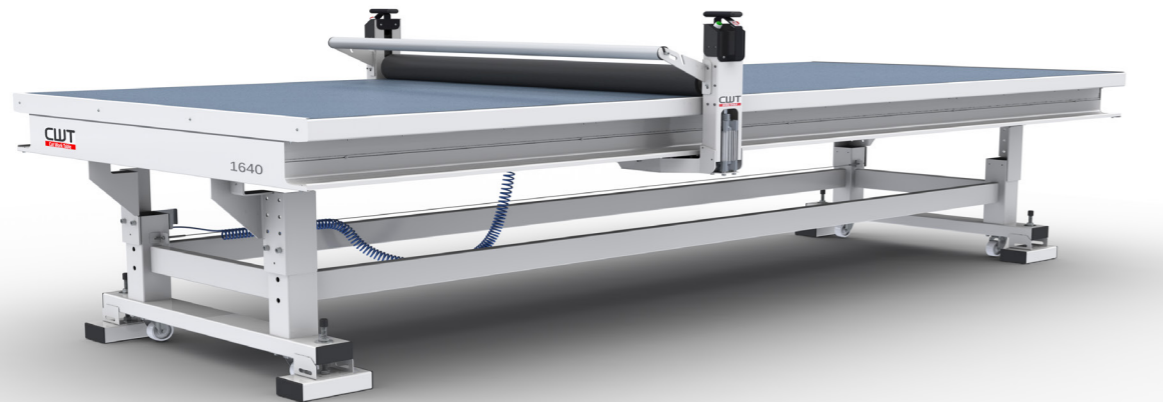

CWT REGULAR

Model	CWT 1630 Regular	CWT 1640 Regular	CWT 2147 Regular
Table length	3 000mm (9ft. 1 in.)	4 000mm (13ft. 1 in.)	4 700mm (15ft. 5 in.)
Table width	1 600mm (5ft. 3 in.)	1 600mm (5ft. 3 in.)	2 100mm (6ft. 1 in.)
Length of working area	2 560mm (8ft. 5 in.)	3 560mm (11ft. 8 in.)	4 260mm (13ft. 12 in.)
Width of working area/roller width	1 560mm (5ft. 1.5 in.)	1 560mm (5ft. 1.5 in.)	2 050mm (6ft. 9 in.)
Max. Thickness of substrate	0-70mm (0-2.8 in.)	0-70mm (0-2.8 in.)	0-70mm (0-2.8 in.)
Work height	744-950mm (2ft.5 in. - 3ft.1 in.)	744-950mm (2ft.5 in. - 3ft.1 in.)	744-950mm (2ft.5 in. - 3ft.1 in.)
Work height adjustment	Manual - 4 steps	Manual - 4 steps	Manual - 4 steps
Bed surface	Safety glass + Cutting mat	Safety glass + Cutting mat	Safety glass + Cutting mat
Pressure control	Pneumatic	Pneumatic	Pneumatic
Roll holder for glide beam	Included	Included	Included
Warranty	3 Year warranty	3 Year warranty	3 Year warranty

OPTIONS

Premium Upgrade kit *	Option	Option	Option
CWT Lift kit, electronic work height adjustment	Option	Option	Option
Silent Compressor	Option	Option	Option
Roll Cradle 450	Option	Option	Option
Lower Roll Holder	Option	Option	Option
CWT Cut, long side **	Option	Option	Option
CWT Cut, short side **	Option	Option	Option
Cutter Bench for 1600 series ***	Option	Option	N/A

* Premium upgrade kit includes: LED illuminated worktable, Lower roll holder and Roll Cradle 1400.

** Brackets for Linear Cutter, available in two versions and are sold separately for the long side and short side.

*** A bracket that fits a wide range of cutters and slitters, such as the Inqlet InBest Pro Cutter Bar™, and KeenCut Evolution2 and Evolution3™ SmartFold.

ADVANTAGE SERIES

PNEUMATIC FLATBED APPLICATOR AND WORKTABLE

Our smallest applicator is still a robust production machine built for uninterrupted long shifts. It offers affordable access to flatbed technology and is compact, making it an ideal choice for smaller or narrow spaces. This machine is perfect for producing smaller signs, yard signs, posters and road signs.

It comes with an illuminated tabletop and casters as standard features, and the CWT 1016 model includes a convenient tool shelf.



Tested and proven!

Complies with CE, UL, ISO 9001 and ISO 14001.

“The CWT worktable is perfect for our space”

Lihn & Van Tran - Owners Sunsigns, Seattle, USA



CWT 1016 Advantage



CWT 1428 Advantage

CWT ADVANTAGE

Model	CWT 1016 Advantage	CWT 1428 Advantage
Table length	1 640mm (5ft. 4in.)	2 850mm (9ft. 4in.)
Table width	990mm (3ft. 3in.)	1 450mm (4ft. 9in.)
Length of working area	1 340mm (4ft. 5in.)	2 570mm (8ft. 5in.)
Width of working area/roller width	950mm (3ft. 1in.)	1 400mm (4ft. 7in.)
Max. Thickness of substrate	0-50mm (0-2in.)	0-50mm (0-2in.)
Work height	795 - 895mm (2ft. 7in. - 2ft. 9in.)	795 - 895mm (2ft. 7in. - 2ft. 9in.)
Work height adjustment	Manual - 3 steps	Manual - 3 steps
Bed surface	Safety glass + Cutting mat	Safety glass + Cutting mat
Pressure control	Pneumatic	Pneumatic
Roll holder for glide beam	Included	Included
CWT Light, illuminated worktable	Included	Included
Tool shelf	Included	N/A
Warranty	3 Year warranty	3 Year warranty

OPTIONS

Roll Cradle 450	Option	Option
Silent Compressor	Option	Option
CWT Cut, long side *	Option	Option
CWT Cut, short side *	Option	Option

* Brackets for Linear Cutter, available in two versions and are sold separately for the long side and short side.

LINEAR CUTTER SERIES

TRIMMER FOR LARGE FORMAT GRAPHICS

CWT Linear Cutter is a perfect tool for trimming soft and flexible substrates such as vinyl and banners, and also a variety of rigid and semi-rigid materials such as boards, including extruded PVC, corrugated plastic and foam board.

CUTS A VARIETY OF SUBSTRATES:

- Flute board
- Gator board
- Cardboard
- Extruded PVC
- Magnetic sheets
- Laminates
- Banners
- Canvas
- Leather
- Rubber
- Textiles
- Vinyl
- Mesh
- Paper

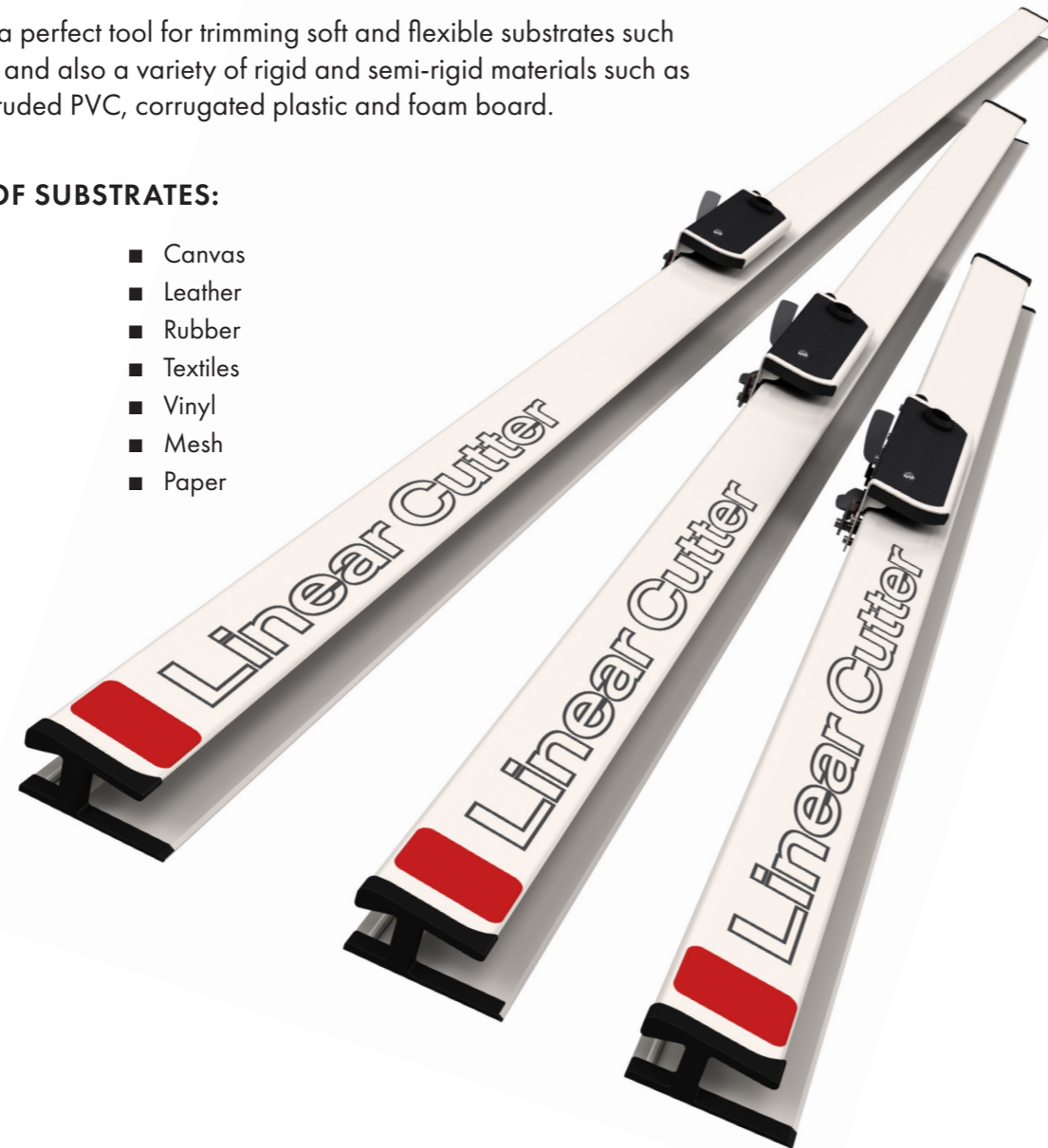

CWT LINEAR CUTTER

Model	D100	Y170	B250	R330
Cut length	1 000mm (3ft. 3in.)	1 700mm (5ft. 7in.)	2 500mm (8ft. 2in.)	3 300mm (10ft. 9in.)
Warranty	1 Year warranty	1 Year warranty	1 Year warranty	1 Year warranty

Linear Cutter Set*

Spare blades "Straight", standard blade, 10 pcs

Spare blades "Hook", 10 pcs

Spare blades "Concave", 10 pcs

* Includes D100, Y170, B250, R330, 1 x Cutter Head and 1 x Extension stick.

BRACKETS FOR CWT WORKTABLE INTEGRATION

Convenient and fast connection brackets are available for our trimmer CWT Linear Cutter. Our range of Linear Cutters can be integrated into the short and long sides of the Premium, Regular and Advantage series using our optional CWT Cut brackets for Linear Cutter.

Model	Long side	Short side
CWT Cut, brackets for Adv./Reg./Prem. series	Option	Option

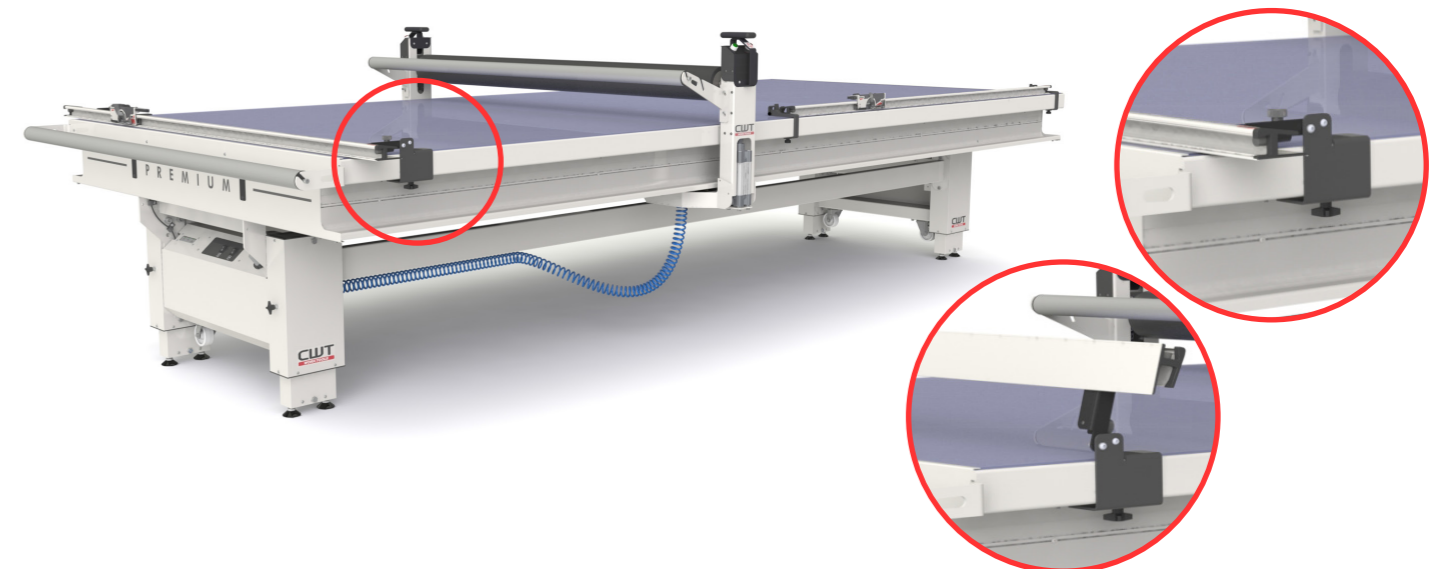

ORIGINAL ACCESSORIES



COMPRESSOR

Silent and oil-free stand-alone compressor.

Silent Compressor

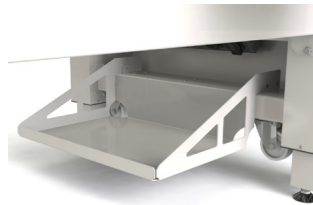

COMPRESSOR SHELF

Integrated underneath, the compressor is mounted to this shelf and moves along with the worktable, providing mobility and saving space.

Compressor Shelf for Premium 1700 series

Compressor Shelf for Regular 1700 series



ROLL CRADLE

The perfect addition to any worktable! Allows for easy unrolling, inspection and re-rolling of media and prints without the damage caused by unnecessary handling.

Roll Cradle 450, 1 pcs Width 450mm (18in.)

Roll Cradle 450, 2 pcs Width 450mm (18in.)

Roll Cradle 1400, 1 pcs Width 1400mm (55in.)



STICKY CLEANER

Cleaning roller and cleaning pads for a dust-free surface. Now equipped with an extension handle, our sticky cleaner offers improved reach across the working area.

Sticky Cleaner 254 Width 254mm (10in.)

Sticky Cleaner 360 Width 360mm (14in.)

Sticky pads 50 sheets

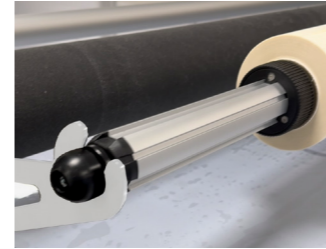

PRO SHAFT 1700

Tensioning shaft with brake and flange guide is used to hold media on the glide beam media holder, improving tracking and lamination quality for larger graphics. Fits media on a standard 3in. core.

Pro Shaft 1700



LONG REACH CUTTER

Easy-to-use trimming tool with a telescopic extension stick, 80-135cm (31-53in.)

Long Reach Cutter

Blades for Long Reach Cutter, 10 pcs

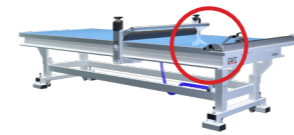

CUTTER BENCH

A bracket that fits a wide range of cutters and slitters, such as the Inget InBest Pro Cutter Bar™, and KeenCut Evolution2 and Evolution3™ SmartFold.

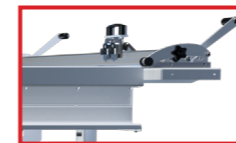

Cutter Bench for Regular 1600 series

Cutter Bench for Premium/Regular 1700 series



CWT LIFT KIT

Electronic height adjustment for CWT Regular Series. This easy to install electrical height adjustment kit gives you great ergonomic features and the possibility for all operators to find their ideal working position. Retrofits all Regular series CWT 1630 up to CWT 2147.

CWT Lift kit, electronic work height adjustment

CUTTING MATS SELF HEALING

Original cutting mats from CWT Worktools are tested and proven for guaranteed performance. They can be used on any worktable or flatbed applicator and are available in many standard as well as custom-made sizes. Most importantly, our cutting mats do not contain any harmful softeners (non-phthalate), making them safe to use.

Remember to replace the cutting mat when necessary, as a worn mat may affect lamination quality.



CWT ORIGINAL CUTTING MATS

Model	Size
CWT1016 Advantage	985x1770 mm, ±5mm
CWT1428 Advantage	1445x2880 mm, ±5mm
CWT1630 Regular	1570x3030 mm, ±5mm
CWT1640 Regular	1570x4040 mm, ±5mm
CWT1647 Regular	1570x4770 mm, ±5mm
CWT1840 Regular	1770x4040 mm, ±5mm
CWT1847 Regular	1770x4770 mm, ±5mm
CWT2140 Regular	2090x4040 mm, ±5mm
CWT2147 Regular	2090x4770 mm, ±5mm
CWT1736 Platinum	1670x3690 mm, ±5mm
CWT1730 Evolution	1720x3170 mm, ±5mm
CWT1737 Evolution	1720x3750 mm, ±5mm
CWT1748 Evolution	1720x4950 mm, ±5mm
CWT1730 Premium / Regular	1695 x 3030 mm, ±5mm
CWT1736 Premium / Regular	1695 x 3630 mm, ±5mm
CWT1740 Premium / Regular	1695 x 4040 mm, ±5mm
CWT1747 Premium / Regular	1695 x 4750 mm, ±5mm

CUSTOMER SUCCESS STORIES

“We have increased our productivity by 70-80 %”

Thanks to the semi-automated laminating process, our CWT Flatbed Applicator has boosted our productivity by 70-80%, making it the primary workspace and central component of our production process.

Frédéric Brülhart - CEO, SICHTBAR Beschriftung, Berne, Switzerland

“We just love our CWT Flatbed Applicator”

It is one of the best time-saving pieces of sign manufacturing equipment we have purchased in twenty-five years. It has halved our production time. What took two people to install is now completed by one person in less time.

Kevin Spahr - Sr. Graphics and Signage Manager, Cvg airport, Cincinnati, Kentucky, USA.

“CWT has easily knocked off 50-75 % of the time to produce a sign”

We’ve had our CWT Flatbed Applicator for about six months now, and we are extremely satisfied with our purchase. With this equipment, I no longer need to consider buying the roll laminator we had planned for. Additionally, we’ve eliminated the issue of bubbles when laying down vinyl on any substrate. Our most extensive project thus far was a 2 x 12 ft. aluminum composite sign, onto which we applied vinyl that was also laminated. Despite the table being only 12 feet long, we managed the project by working on sections at a time and moving the material down the worktable. Overall, it has significantly reduced the time required to produce a sign, by an estimated 50-75 %.

Fran Gavin - Sir Speedy Print, Pennsauken, New Jersey, USA

“Our CWT worktable is simple, smart and reliable”

At SignViz, a division of Paramount Safety (Pro Choice), we manufacture a wide range of Safety Signs and General Signage across Australasia using various substrates. Our main focus is laminating self adhesive vinyl to materials like polypropylene, metal, and aluminium. Recently, we acquired a CWT worktable to replace two older front-loading laminators. Our primary goal was to boost productivity, minimize waste, and reduce the need for multiple staff members on large projects. With the new laminator, one staff member can handle all laminating tasks efficiently, resulting in minimal waste and increased team confidence. The project met all targets within budget and timeline expectations. Comprehensive training was provided, although the equipment’s simplicity and reliability made it easy for everyone to operate and appreciate.

Kevin Brettell - General Print Manager, Paramount Safety, Sydney Australia



MADE IN SWEDEN



CWT Worktools has been approved by Lloyd's Register in accordance with the following standards: ISO 14001:2015 and ISO 9001:2015

Approval number(s):
ISO 14001 – 00009781 and ISO 9001 – 00009782



CWT Worktools is proud to announce that **CWT 1730** part of the 1700 Premium Series received a PRINTING United Alliance 2023 Pinnacle Product Award in the category of Non-Output.

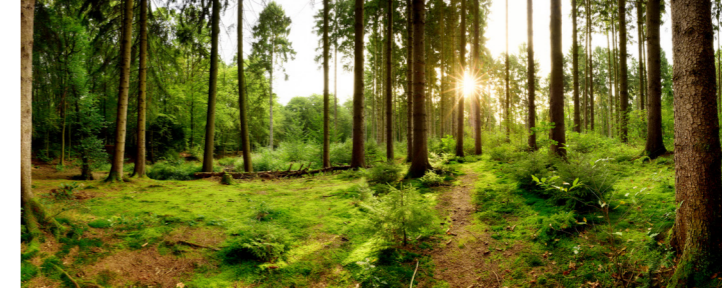

RESPONSIBILITY



CWT Worktools has received a 2021 Silver Medal from EcoVadis. This recognition is a testament to our continuous efforts in the field of sustainability and corporate social responsibility, which we are proud of.



CWT Worktools is actively working towards compliance with the UN's Sustainable Development Goals by 2030.

Interim target 12.2
Subgoals 12.5/17.3/17.7 by 2030



HEADQUARTERS

CWT Worktools
Årstidsvägen 8
SE-665 35 Kil, Sweden
Phone: +46 554 333 90
E-mail: info@cwtworktools.com
cwtworktools.com

Distributor/dealer: